

# Wavecom



## Wavecom Handheld Portable Appliance Testers

# User Manual

+ Certificate of Warranty and Product Support Information

# Wavecom Certificate of Warranty

## **Your Wavecom Appliance Tester comes with a conditional 36 month warranty.**

Your warranty applies unconditionally for 12 months from the date of purchase. This can be extended an additional 12 months if your Tester is calibrated within 12 months of the date of purchase.

This can be extended a **further** 12 months if you calibrate you tester a second time within 24 months of the date of purchase.

The Manufacturer (Wavecom Instruments Pty. Ltd.) warrants its products against defects in materials and workmanship for a period of 12 months from the date of purchase. This period can be extended based on the conditions above or by the Manufacturer's discretion. During the warranty period, the Manufacturer will repair (or at its option replace at no charge) the product that proves to be defective. This warranty does not apply if the product has been damaged by accident, abuse, misuse or mis-application or as a result of service or modification by anyone other than the Manufacturer of this tester.

The TnT & TnP Product Range of devices or its Manufacturer is not responsible for incidental or consequential damages resulting from the breach of any express or implied warranty, including damage to property and to the extent permitted by law, damages for personal injury. The distributors of this product cannot assume liability or responsibility for any loss of damage resulting from the use of this device.

The Manufacturer reserves the right to discontinue models, change specifications, price or designs at any time without notice or obligation.

# Product Support

At Wavecom we take great pride in our customer service and support. We provide assistance, troubleshooting and support over the phone, via Skype or Facetime, via email or in person to help you get the most from your Wavecom Portable Appliance Tester. To be eligible for our support services you must register your product.

You can register via the WinPATS App (this is done automatically during the setup process), or online at:

[https://www.wavecom.com.au/wcm\\_product\\_registration.php](https://www.wavecom.com.au/wcm_product_registration.php)

## Safety Information

Our appliance testers have been designed to meet stringent safety requirements, however no device can completely protect you from the consequences of incorrect use. The testing of electrical appliances requires that extra care and caution is taken at all times to ensure personal safety.

The Manufacturer also advises that appliance testing should be conducted by a *Competent Person* who is suitably trained (see P.5 AS/NZ 3760:2022 for the definition of *Competent Person*), as well as any additional legislation or rulings in different states. If in doubt, the manufacturer suggests the user contact their responsible authority.

For maximum safety, always ensure that the following advice is followed:

- The equipment being tested is in good condition and passes a visual check.
- All instructions are read, understood and followed.
- The power supply connections are always checked - if the N-E (middle) LED Indicator flashes red, do not proceed before consulting the manual.
- Always use specified fuses and protection devices.
- Do not use leads that require repair or are damaged.
- If you are unsure, call a licensed Engineer/Electrician.

## Important Calibration Information

Your Wavecom Appliance Tester should be calibrated every 12 months. A correctly calibrated tester is essential for ensuring testing accuracy is maintained, and for complying with the AS/NZS 3760:2022.

To book your tester in for calibration, go to:

<https://www.wavecom.com.au/calibrations>

Then, send your tester to your nearest calibration service centre:

***For Western Australian customers:***

Wavecom WA Calibrations  
Unit 2/17 Casino Street,  
Welshpool, WA 6016

***For all other customers:***

Wavecom Calibrations  
257 Grange Road,  
Findon, SA 5023

## Key

Throughout this manual the following symbols are used to denote which tester the section applies to:

**TnT EL**

**TnT RCD**

**TnT Titan**

<b>Important Information</b>	<b>5</b>
Contents	5
Diagrams	6
Precautions	6
Using the Tablet	8
<b>Operating Your Tester</b>	<b>9</b>
Powering on the Tester	9
Using the TnT Titan with WinPATS	9
Setting up the Barcode Scanner	15
LED Indicators	16
Testing Menu – Main Menu A	17
Testing Menu – Main Menu B	18
Meter Mode <sup>®</sup> [Not available in Battery Mode]	23
<b>Specifications</b>	<b>25</b>
<b>Technical Information</b>	<b>26</b>
Visual Inspection	26
Class 1 (Earthed Appliance) Construction	26
Class 2 (Double Insulated) Construction	27
Testing of Electrical Equipment	27
Leakage Test	27
Earth Continuity Test	28
3 Phase Testing	28
Integrated Tests	29
No Connection No Test	29
<b>Wavecom Tags</b>	<b>30</b>
<b>Tester Serial, WinPATS Coupon Code &amp; Purchase Information</b>	<b>Rear Cover</b>

# Important Information

## Contents

**TnT EL**

**TnT RCD**

**TnT Titan**

- Wavecom Portable Appliance Tester
- IEC Test Lead (500mm Orange)
- Earth Lead with Alligator Clips (1800mm Black)
- IEC Power Cable
- WinPATS voucher for App License through Google Playstore  
*(TnT Titan Only)*
- 8 inch 4G-Ready Android tablet with mount accessories  
*(TnT Titan Only)*
- Tablet Charging Cable *(TnT Titan Only)*
- USB-OTG Adapter *(TnT Titan Only)*
- Black 16A Power Adaptor with 10A IEC Lead *(20A Units Only)*
- 24 Month Conditional Warranty
- Manufacturer's 1st Calibration Certificate (Valid for 12 months from purchase)
- User Manual
- Quick Start Guide
- Welcome Letter

## Diagrams

**TnT EL**

**TnT RCD**

**TnT Titan**

### Tester Diagram

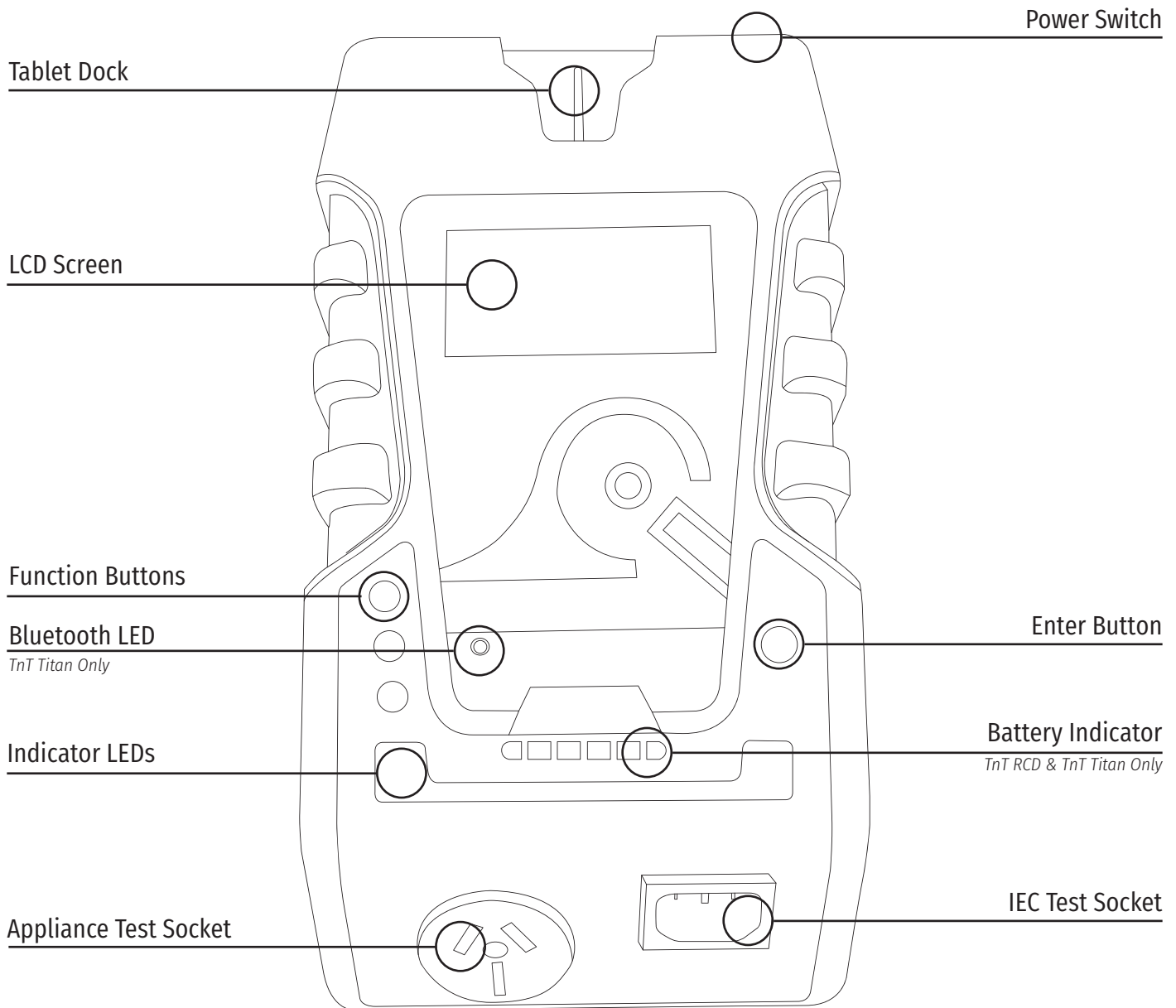

## Rear Panel of Tester Diagram

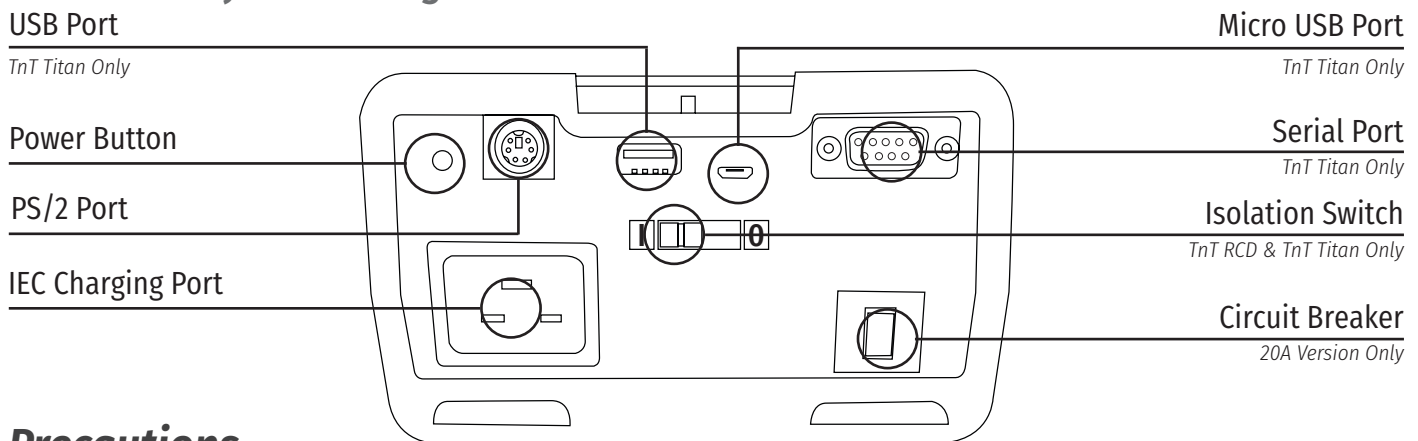

## Precautions

### Using your Tester on Mains Power

TnT EL

TnT RCD

TnT Titan

To use your Wavecom Appliance Tester on mains power, simply plug in the supplied power cable and connect it to a mains power outlet. Your Wavecom Appliance Tester will automatically connect to mains power and begin charging the battery.

### Using the Lithium Ion Battery

TnT RCD

TnT Titan

When unit is not connected to mains, simply press and hold the power button at the rear of the tester till unit you hear a beep and the LCD screen turns on. Use the same button to turn off the unit when in battery mode. Mains Supply tests, Leakage tests and Meter Mode functions are not available on battery power. To perform RCD Tests, the TnT RCD/TnT Titan are required to be connected to mains power.

**Important: Ensure that the battery isolation switch is ON while operating the unit & performing tests. The isolation switch is located on the rear of the tester.**

### To Charge the Battery

Internal lithium-ion battery (98Wh, 6700mAh) can power the TnT RCD/TnT Titan for around 3000 sets of tests. The battery is charged simply by plugging the TnT RCD/TnT Titan into mains power, and it takes around four hours to fully charge.

*Note: Turning off the Isolation Switch (located on the rear of the tester) isolates the battery completely and prevents the battery from charging.*

While your TnT RCD/TnT Titan is charging and not in use, the display can be turned off by pressing and holding the ENTER button until you hear a beep and the LCD screen backlight turns off. You will then see charging information displayed on the screen. Once the battery is fully charged and it is still connected to mains, battery symbol will convert to plug symbol. It is advised not to put unit to charge when it is unattended or overnight.

## Transporting Lithium Ion Battery Products

It has come to the attention of Wavecom Instruments Pty Ltd, that products containing batteries are being shipped by customers through air freight. It is our understanding that, for the purpose of air transport, lithium ion batteries are considered **dangerous goods** under the International Air Transport Authority (IATA)

regulations. It is the responsibility of the shipper to ensure that the product being shipped and the packaging used comply with all regulations, noting that **extensive penalties can be imposed by the relevant authorities for any breach.**

The IATA and other laws and regulations covering the transport of goods are very comprehensive, and Wavecom Instruments makes no warranty that these regulations will permit particular shipments of its products by air freight. **Lithium ion batteries are not allowed to be transported by air.** Products that contain internal batteries are allowed, as long as the batteries are not damaged.

Should you require further information on the relevant regulations and requirements, please contact your dangerous goods adviser and/or review the IATA website: [www.iata.org/publications/dgr/Pages/index.aspx](http://www.iata.org/publications/dgr/Pages/index.aspx)

This is not intended to constitute legal advice, and you should obtain your own professional advice. Please contact Wavecom Pty Ltd for more information.

## Competent Person

**TnT EL****TnT RCD****TnT Titan**

To ensure that all electrical equipment or devices are inspected, tested and tagged correctly, regulations require that a 'competent person' such as a Licensed Electrician be employed to perform the required tests. Please refer to the above definition as described in the current AS/NZS 3760:2022 Standard and in addition, to any other local legislation or jurisdictions as may be relevant in your State.

A person competent to undertake Inspection and Testing of electrical equipment must have:

- Knowledge and practical experience of electricity and its hazards.
- A clear understanding of precautions to avoid danger.
- The ability to recognise at all times whether or not it is safe for work to continue.
- The ability to carry out visual examinations of electrical equipment.
- The ability to distinguish between electrical equipment that is double insulated and equipment that is earthed as well as being able to identify the appropriate test for each type.
- The competency to safely carry out the Earthing Continuity, Insulation Resistance or Leakage Test and RCD tests on electrical equipment.
- The knowledge of how to use the relevant testing instruments, interpret and record the results for compliance with the Standard/Workplace requirements.
- The knowledge to be able to correctly recommend the frequency of testing required.

Due to the potential hazards of electrical testing, due care must be taken at all times.

## Warnings

**TnT EL****TnT RCD****TnT Titan**

**Operating Environment: Charging – 0° to ~45°C; Discharging -20°to ~ 60°C.**

Please ensure the unit is stored in compliance with the operating environment requirements and in a safe and secure location.

When sending your Wavecom Appliance Tester for calibration, please turn off the battery isolation switch which is located on the rear panel of the tester. If you have any questions about the battery of your tester please contact Wavecom for further advice.



## Replacing Fuses

TnT EL

TnT RCD

TnT Titan

From time to time an appliance may cause an internal fuse within your TnP 3PLM to break. When this occurs you will need to replace the fuse. If you prefer you can return your tester to Wavecom and we can replace the fuse for you, or if you wish you may replace the fuse.

## Using the Tablet

TnT Titan

The TnT Titan comes with an Android tablet to be used with the WinPATS App to control your tester, save your test results and generate reports. In the next section you will find a short introduction to using the TnT Titan with your tablet, and more detailed, step by step guides are available on our website - [www.wavecom.com.au](http://www.wavecom.com.au)

The tablet provided is intended for use with WinPATS only - using additional apps (other than those already installed) may interfere with the functions of WinPATS and may slow down the app significantly. We strongly recommend that you do not install other apps on this tablet, to ensure the stable operation of the WinPATS App.

Before using your tablet with WinPATS, you must set it up as per the manufacturers instructions, and connect it to the internet (via 4G or wifi). We also recommend that the tablet is fully charged before the first use.

Your tablet warranty is covered by the manufacturer (Telstra). While Wavecom are happy to provide support to help you use your tablet for WinPATS, any issues that arise from the tablet (and not the WinPATS App) will need to be resolved with the manufacturer.

With your TnT Titan you will have two tablet docking accessories. These are to be attached to your tablet so you can secure your tablet to your TnT Titan.

To attach the docking accessories, we recommend docking them to the TnT Titan as shown below.

Then, peel off the backing plastic to expose the adhesive and place your tablet onto the docking accessories. Take care to ensure that your tablet's camera and charging port are not blocked by the docking accessories.

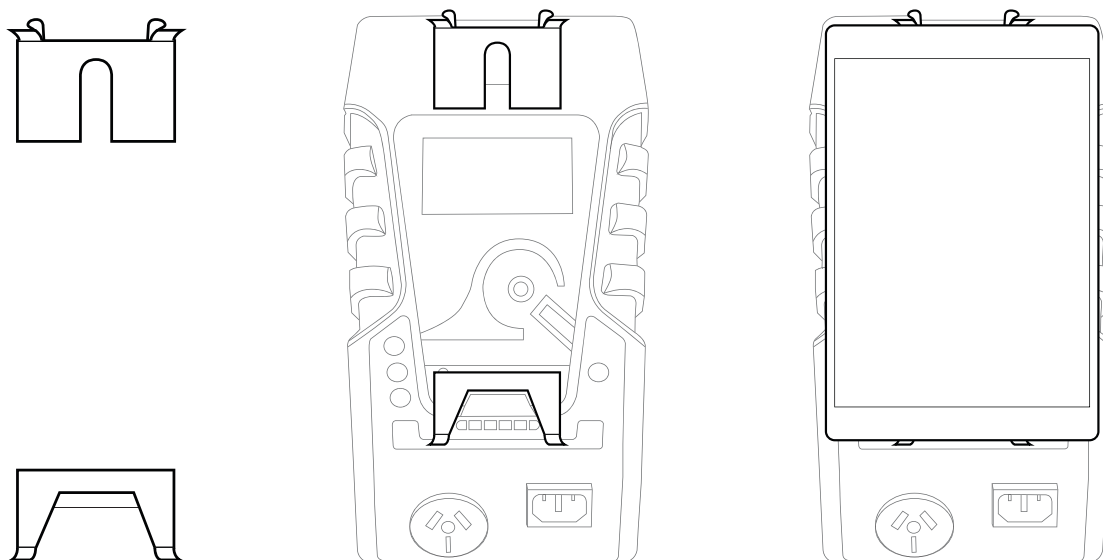



# Operating your Wavecom Appliance Tester

## Powering on the Tester

**TnT EL****TnT RCD****TnT Titan**

To use your Wavecom Appliance Tester, ensure the isolation switch (located on the rear of the tester) is switched ON. We recommend that your Wavecom Appliance Tester is fully charged before the first use.

Your Wavecom Appliance Tester will be powered on automatically when you connect it to mains power.

To power on TnT RCD or TnT Titan in battery mode, press and hold the rear power button until the unit beeps and the LCD screen turns on.

## Using your TnT Titan with the new WinPATS App

**TnT Titan**

Setting up the new WinPATS App is simple, but can take some time. We recommend setting up WinPATS before you need to use it on site. You will need to download “WinPATS Pro” from the Google Play Store onto your Android tablet. On our website, you can find a set of videos that will guide you through the various functions and features of the new WinPATS App. This guide will walk through setting up WinPATS and connecting to your tester.

Once you have downloaded the WinPATS App, open the app and create up a 4 digit pin code.

Next, it's time to set up your Company Account. If your employer or organisation has an account already, you can log in now using the details provided to you. Otherwise, tap Register Company to set up your Company Account - you will be prompted to enable WinPATS' permissions - this allows you to use the full set of WinPATS features.

Now, fill in your details - a valid ABN is required to register a new company. You should use the address and contact details of your head office. Once your details are entered, check they are correct, then tap Register.

You will be sent a One Time Password (OTP) to the email you entered in the previous step. This is used to verify your email address - enter the OTP to continue. This OTP is only valid for 10 minutes - if your OTP expires, simply go back and then tap 'Register' again. If you don't see your OTP email, check your spam folder.

Now you can pay for your WinPATS License - you should have a coupon code on the rear cover of this booklet which provides you with one free license for the WinPATS App. Your coupon code is linked to your tester, and you will need to connect your Android tablet to your TnT Titan to authenticate your code. Using the USB-OTG cable supplied with your tester, connect your tablet to your tester in the following chain: *Tablet > USB-OTG > USB-A to Micro USB Cable > Micro USB port of your TnT Titan (located on the rear of your tester)*. See diagram on page 10. Once your TnT Titan is connected to your tablet, enter your coupon code and tap APPLY. You should see the Total Amount number drop to zero. Tap PAY to proceed.

Once you have entered your code or paid, you can now Log In and set up your password. Enter the Company ID and temporary Password which was emailed to you, which will enable you to log in for the first time. You will now be prompted to set up a new password.

You can now set up your User Account - this is your individual profile. If you are the first or the only Test and Tag technician at your organisation, you should set yourself as an 'ADMIN' user, which will allow you to use the

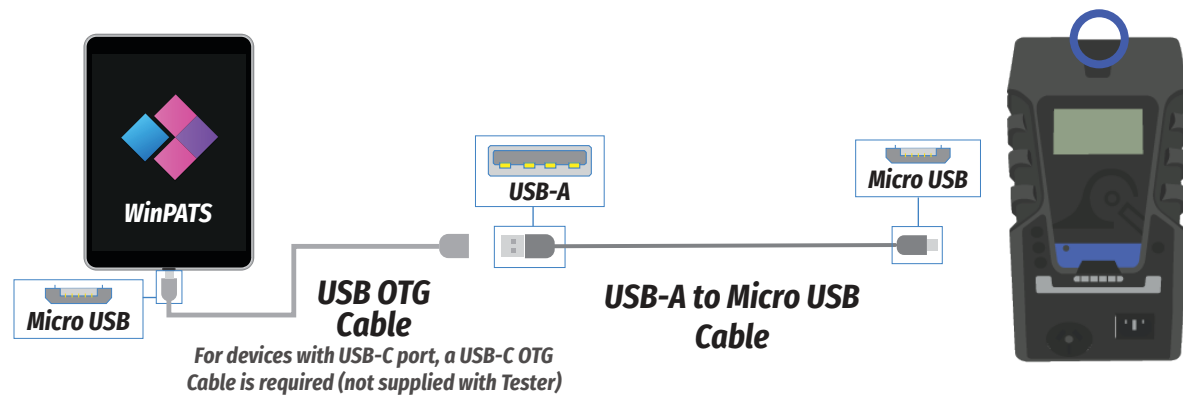

full features of WinPATS. Technician users have reduced access to features - this is designed for organisations with multiple technicians and/or multiple sites.

Once your details are complete, tap ADD to create your account. Confirm your details are correct, then tap CONFIRM to finish registering your user account.

When you start WinPATS for the first time you'll be required to perform a data sync. This creates a new cloud database for you or connects your WinPATS App to your company's existing database. If your database has many items, this may take up to 5 minutes, but usually only takes a few seconds.

## Connecting the TnT Titan to your tablet via Bluetooth

To control your TnT Titan via Bluetooth, you will need to perform a short setup procedure. Ensure you have both your tablet with WinPATS installed, and your TnT Titan in front of you.

### Go to the Bluetooth settings in your Tablet's settings menu

Ensure that Bluetooth is enabled, then select your TnT Titan from the list of available devices (ensure you select the correct tester by referring to the serial number. Your TnT Titan's serial number is located on the bottom of your tester, and on the rear cover of this booklet).

You may now be prompted to pair your two devices using a PIN code. If so, your TnT Titan will display a code on the screen. Enter this code into WinPATS and tap OK. You will be asked to confirm the connection - tap Confirm after checking the details are correct.

*Note: If you have any issues with the PIN code, you can disable this function from the TnT Titan settings menu. Power on your TnT Titan, then hold Enter and press F2 to open the settings menu. Navigate to 'Bluetooth Configuration' and press Enter. When prompted with 'Use Security PIN for Bluetooth' select 'Disable' by pressing F3.*

### Go to the WinPATS App

To connect your TnT Titan, go to the Test menu in the WinPATS App (at the top of the screen). You should be prompted to connect a Wavecom Appliance Tester as soon as you open the Test Menu for the first time. Tap 'BLUETOOTH' to begin the Bluetooth setup process.

WinPATS will scan for any available TnT or TnP testers and display them in a list - select your tester from the list by tapping it. If you see multiple TnT or TnP products in the list, use the serial number of your TnT Titan to identify your tester.

You will now be asked to register your TnT Titan - this allows you to receive product support, service and

calibration reminders from Wavecom. Once complete, tap Register. You're now ready to start testing with WinPATS.

**Once your TnT Titan is connected you will not need to follow this procedure every time. If the app is closed via the Exit Button (in the Side Menu) the tester will autoconnect when you next open WinPATS.**

### Connecting the TnT Titan to your Tablet USB

You can also connect to your TnT Titan via USB if needed. Use the following diagrams to connect your TnT Titan to your tablet.

To connect your TnT Titan to your tablet via USB, you will need:

A USB-A TO USB-B CABLE (INCLUDED)

A MICRO-USB TO USB-A CABLE (INCLUDED)

A USB-OTG CABLE (INCLUDED)

Connect your cables in the sequence shown below. Your TnT Titan USB-B port is located inside the storage compartment. Once connected, you will be prompted to enable various permissions - please 'Allow' all of these in order to ensure correct operation. Now, open WinPATS on your tablet. You should see the Test icon and the Print icon (if you connect the printer) at the top of the screen change to green.

If the connection is not automatically recognised, you can begin the connection procedure by going to the Test menu, then tapping 'Connect by USB'. If you still encounter issues, disconnect the USB-OTG cable from the tablet and reconnect it.

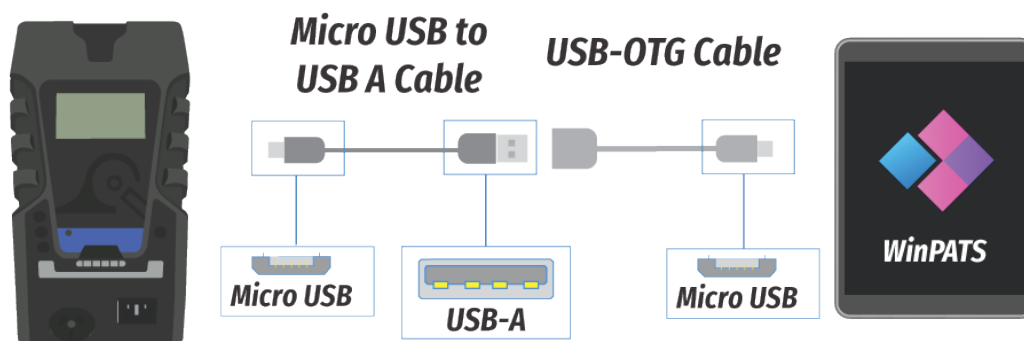

### Connecting your TnT Titan and Printer to your tablet

There are 4 ways to connect the TnT Titan and a printer to your tablet - select the best option for your individual situation.

#### Method 1

For this method you will need:

A USB-A TO USB-B CABLE (INCLUDED)

A USB-OTG CABLE (INCLUDED)

Connect the printer in the sequence shown here, and connect your TnT Titan via Bluetooth as explained on Page 10. Once connected, open WinPATS on your tablet. You should see the Test icon and the Print icon at the top of the screen change to green.

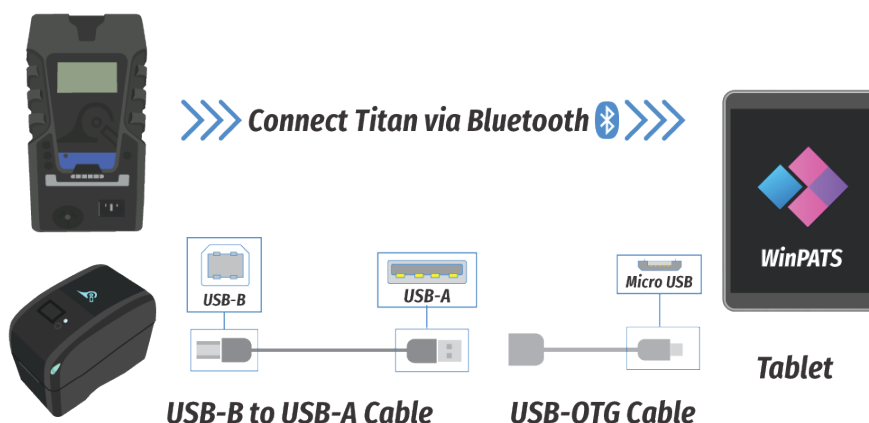

*Method 2*

For this method you will need:  
A WAVECOM PRINTER SERIAL CABLE

Connect your Printer to the TnT Titan using the Wavecom Serial Cable (serial ports are on the rear of the Printer and the TnT Titan). Once connected, open WinPATS on your tablet. You should see the Test icon and the Print icon at the top of the screen change to green.

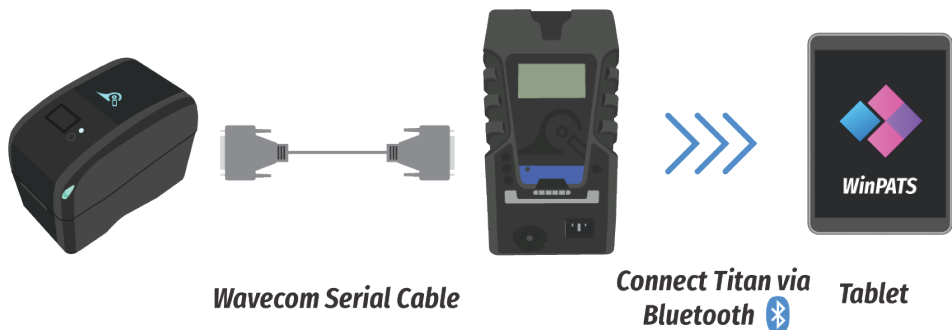

*Method 3*

For this method you will need:

- A USB-A TO USB-B CABLE (INCLUDED)
- A MICRO-USB TO USB-A CABLE (INCLUDED)
- A USB HUB OR USB SPLITTER CABLE (NOT INCLUDED)

Connect your cables in the sequence shown below. The Micro USB port of the TnT Titan is located at the rear of the tester, and the Printer USB-B port is located at the rear of the printer. Once connected, open WinPATS on your tablet. You should see the Test icon and the Print icon at the top of the screen change to green.

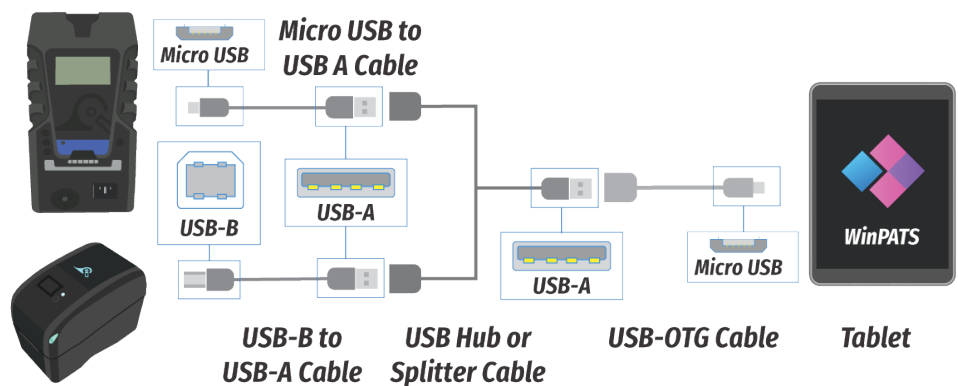

*Method 4*

For this method you will need:

THE WAVECOM TT-040-50BB BLUETOOTH PRINTER

Connect your the TnT Titan to your tablet via Bluetooth, as explained on Page 10.

Connect your Bluetooth compatible Wavecom Printer by following the same directions as connecting the TnT Titan.

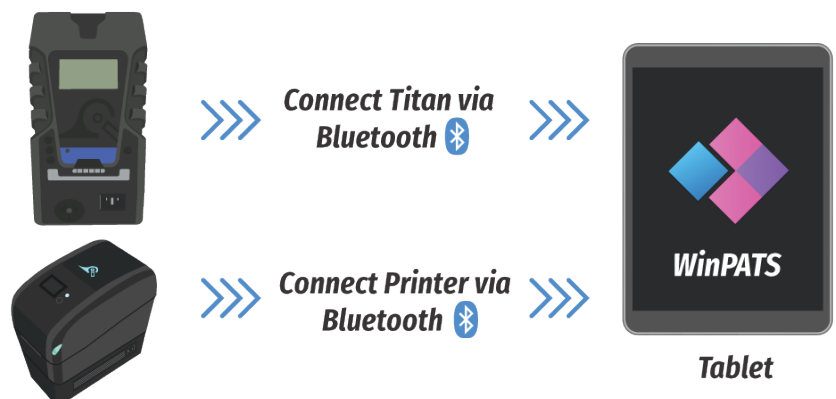

## Adding a User

*Note: You will have already created a WinPATS User during the setup process. Follow this process to add another user, or to edit the details of your users. This feature requires Admin access, Technician level users will need to enter the Company Password to access this feature.*

**Important: To avoid duplication of data a User must only be logged in and active on one tablet at a time.**

To add a new User to WinPATS, open the Side Menu, then tap the User Profile Picture at the top of the menu. If required, enter the Company Password. You can now view the Users at your company using the dropdown menu, then edit, suspend (lock the user but keep the profile) or delete the user.

To add a new User, tap the '+' symbol next to the dropdown menu. Fill out the form, including selecting a profile picture and assigning Admin permissions (if required), then tap 'Add' when complete. You can now select this user from the dropdown menu.

When changing users, select your user from the menu, then tap 'Confirm' to switch to that user.

## Adding a Customer

*Note: You can also add a new customer during the 'Adding an Item' process if needed.*

To add a new Customer to WinPATS, open the Side Menu, then tap 'Database+', then tap 'Customers'. You can view your existing customers in the list, and add a Site, edit their details and delete the customer by tapping a customer in the list.

Tap 'Add Customer' to open the new Customer form. Fill out the form - please note, a valid ABN is required to add a new customer. When complete, tap 'Add Customer'. You will now be able to assign sites and items to this customer.

## Adding a Site

*Note: You can also add a new site during the 'Adding an Item' process if needed.*

To add a new Site to WinPATS, open the Side Menu, then tap 'Database+', then tap 'Sites'. You can view your existing sites (and filter by Customer) in the list, and edit or delete your sites by tapping a site in the list.

Tap 'Add Site' to open the new Site form. Fill out the form, and tap 'Add Site' when complete. You will now be able to assign locations (places within a site) and items to this customer.

## Entering a New Item

To add a new item to WinPATS, open the Side Menu, then tap 'Database+', then tap 'Add Equipment'. Fill out the form, including selecting the Customer and Site. Set the Current Status, Test Frequency and Test Sequence - this allows WinPATS to tell your TnT Titan which test to run when you test this item.

If you wish to add multiple versions of your item (for instance, if your company has purchased 5 identical new printers), you can change 'Add Multiple Identical Equipment' to 'Yes'.

When you have added all the information to your item, tap 'Add Equipment'. You can now test this item by searching for it in your database.

## Testing Items

*Note: There are multiple ways an item can be tested using WinPATS. This part will cover the two most common methods. Both of these methods require that your TnT Titan to be connected to your tablet (see above 'Connecting via Bluetooth').*

### Testing from the Test Menu

At the top of the WinPATS home screen you should see the 'Test' icon. Tap this to open the Test Menu. Here you will see 6 options:

<b>Quick Test</b>	This allows you to run a test first, then create an item or assign the results to an existing item after the test is complete
<b>New Test</b>	This allows you to select an existing item from your database, or add a new item, then conduct tests on it. Using this method means you can use the 'Test Procedure' assigned to the item to run the test, meaning you don't need to manually select a test.
<b>New to Service</b>	This is the same as 'New Test', but will categorise the item as 'New to Service'
<b>Out of Service</b>	This is the same as 'New Test', but will categorise the item as 'Out of Service'
<b>Visual Check Only</b>	This is the same as 'New Test', but will categorise the item as 'Visual Check Only'
<b>Data Logger</b>	This feature is still in production

Select the best option for your situation. If you select **Quick Test**, select the test you wish to conduct from the list. Set up the item to be tested by plugging it into the TnT Titan (along with any accessories as required), adjust any options (such as test voltage), then tap 'Start Test'.

Conduct the Visual Test, and if the item passes, the test will be conducted in stages automatically, and the results displayed on screen. If you wish to continue without saving, simply tap the 'Home' button. If you wish to save these results, tap 'Save Results'.

You will be taken to a screen where you can either search for an item in your database, or add an existing item. Follow the relevant steps and your test results will be assigned to the item you select/create. If you have a Wavecom tag printer, you can print a tag at the end of this process. Otherwise you can now continue with your testing.

If you select **New Test** (or New to Service, Out of Service, or Visual Check Only), you will create or select the item you wish to test first. Either search for an existing item in your database, or add a new item.

Once you have created/selected the item, review the Assigned Test Sequence and ensure the correct test will be conducted. Set up the item to be tested by plugging it into the TnT Titan (along with any accessories as required) then tap 'Start Test'.

Conduct the Visual Test, and if the item passes, the test will be conducted in stages automatically, and the results displayed on screen. Your results will be saved, and if you have a Wavecom tag printer you can now print your tag (or save it to the Print Queue to print later). You can now continue with your testing.

### Testing from the Item Information Screen

You can also conduct tests from the Item Information Screen. If you: Search for an Item from the Asset Lookup

on the Home Screen, scan a barcode or find the item in your Inventory (Side Menu > Database+ > Inventory). Once you are on the Item Information screen, review the Assigned Test Sequence and ensure the correct test will be conducted.

Set up the item to be tested by plugging it into the TnT Titan (along with any accessories as required) then tap 'Start Test'. Conduct the Visual Test, and if the item passes, the test will be conducted in stages automatically, and the results displayed on screen. Your results will be saved, and if you have a Wavecom tag printer you can now print your tag (or save it to the Print Queue to print later). You can now continue with your testing.

## ***Printing Tags***

If you have a Wavecom Tag Printer, the WinPATS App can print tags to your printer via Bluetooth. You can print tags at the end of a test as part of the testing process, or save tags to print later from the Print Menu.

To print a tag during the test process, carry out the test as described above. Once the test is complete, tap 'Save Result'. After the result is saved, you will see the 'Save Result' button change to 'Print Tag'. To print a tag now, tap this button. To save a tag to print later, tap the arrow at the bottom of the screen (in the centre). This will open a sub menu, including the option 'Print Later'. Tap this to save the tag to print later from the Print Menu.

To access to Print Menu, tap the 'Print' icon at the top of the Home Screen. You will see a list of tags that have been saved to print later. To print a tag from the list, tap on it. You will see a number of options appear: Print Tag, Print Mini and Delete. To print a standard tag, tap 'Print Tag'. To print a small form tag, tap 'Print Mini'. To delete the item from the print menu, tap 'Delete'.

You can also adjust print settings and more by tapping the '⊕ More' symbol above the list of tags.

## ***Editing Items***

Items in your database can be edited from the Inventory screen. To open the Inventory screen, open the Side Menu, tap 'Database+' then 'Inventory'. Double tap (or press and hold) an item in the Inventory list to open the Item Information screen.

You can then tap 'Update Details' to change any of the details of the items. You can then edit any of the fields, and tap 'Update Item' when complete.

You can also edit multiple items at once - view the 'Managing your Inventory with WinPATS' video on the Wavecom Youtube channel for more information.

## ***Deleting Items***

Items in your database can be deleted from the Inventory screen. To open the Inventory screen, open the Side Menu, tap 'Database+' then 'Inventory'. Double tap (or press and hold) an item in the Inventory list to open the Item Information screen. Tap 'Update Details', then scroll to the bottom of the 'Update Details' screen and tap the red Trash icon to delete that item.



## Setting up the Barcode Scanner TnT Titan

You can connect a barcode scanner to your tablet for use with WinPATS. We include a Bluetooth 1662 BT scanner with the TnT Titan Kit, and TnT Titan users can purchase this as an optional extra. You may be able to use other barcode scanners with your TnT Titan however we cannot guarantee every scanner can be connected using this guide, or that they will operate as expected with WinPATS and the TnT Titan.

To set up the Bluetooth connection you will need your tablet and Bluetooth scanner in front of you. The 1662 BT Bluetooth scanner comes with a Quick Start Guide which may be useful for troubleshooting, but you can set up your scanner using the following instructions. We recommend that you ensure the scanner is fully charged before using it on site.

First, ensure the battery is installed in your barcode scanner. The LED on your scanner should begin flashing blue, indicating it is ready to be paired to your tablet. Open the Bluetooth Settings menu of your tablet and turn Bluetooth on (if it is not already on). Tap 'Pair New Device' to begin scanning for Bluetooth devices.

Your scanner should appear in the list - you can identify your scanner by the first 4 numbers "1662" followed by the serial number (e.g 1662CFJ000123). The serial number of your scanner is located on the label of your scanner box. Tap your scanner in the list to pair it with your tablet. If you see a prompt to enter a PIN code, simply tap 'Pair' without entering anything - the PIN setting is disabled by default on the scanner and is not required.

Your scanner should now be paired with your TnT Titan. To test your scanner, open the WinPATS App and return to the Home screen. Scan one of the barcodes on the outside of the scanner box, and you should see the barcode appear in the 'Search Barcode' field on screen.

If you encounter any issues with your scanner, consult the quick start guide included with the scanner, or contact us for support.

### LED Indicators

#### Battery LEDs TnT RCD TnT Titan

The battery LED indicators display how much charge is remaining in your TnT RCD/TnT Titan. Use the table below for reference.

	100% - Battery is fully charged
	80%
	60%
	40%
	20% (LED 2 will be flashing)
	0% (LED 1 will be flashing)

Indicator LEDs



The indicator LEDs are used to display various statuses and results. Please refer to the relevant table below.

TnT EL	TnT RCD	TnT Titan	
			LEDs will flash yellow during tests when running on mains power.
			When an appliance fails a test, the Indicator LEDs will turn red while the test results are on screen
			When an appliance passes a test, the Indicator LEDs will turn green while the test results are on screen

TnT EL	
	TnT EL is on and powered via mains power.

TnT RCD	
	TnT RCD is running on battery power. When the test socket is live during a test, the LEDs will flash white.
	TnT RCD is running on mains power and is charging. LEDs will flash yellow during tests.
	TnT RCD is fully charged.

TnT Titan	
	TnT Titan is running on battery power, no Bluetooth connection. When the test socket is live during a test, the LEDs will flash white.
	TnT Titan is running on battery power, active Bluetooth connection. LEDs will flash blue during tests
	TnT Titan is running on mains power, and is charging, no Bluetooth connection.
	TnT Titan is running on mains power, and is charging, and has an active Bluetooth connection. LEDs will flash solid yellow during tests.
	TnT Titan is fully charged, and has no Bluetooth connection
	TnT Titan is fully charged, and has an active Bluetooth connection

TnT EL	TnT RCD	TnT Titan	
<p>If there is a fault with the mains power connection, you may see one (or more) of the Indicator LEDs turn red. This may indicate a serious issue with the mains power supply - consult a qualified professional before proceeding. This won't apply when using battery power.</p>			
			Standard Mains Supply Test result with no issues.
			N-E Fault - If the N-E light is on, DO NOT PROCEED. The N-E LED will turn red if there is a voltage difference between the neutral and earth, or if there is no earth connected. If you are working from a generator or inverter this is likely to occur - consult a qualified electrician before proceeding.
			If the N-E LED is red, and A-N is green, there is a fault with the Mains Supply
<p>You may also see more than one, or all of these turn red. For more information, see Mains Supply Test (Page 25)</p>			

## Testing Menu – Main Menu A

TnT EL

TnT RCD

TnT Titan

If you are using your TnT Titan with the WinPATS App, you do not need to operate the TnT Titan manually - all functions can be controlled directly from the App.

### Class 1 - Earthed Appliance Test - Menu A - F1

**The Class 1 Test completes the following sequences as part of its procedure:**

- Integrated Supply Mains Test - Refer to Integrated Test section
- Integrated NCNT Test - Refer to Integrated Test section
- Earth Bond Test (@ 200mA): 200mA test current, pass level less than 1Ω
- Insulation Test (@ 250V or 500V): pass level greater than 1MΩ

*Note: 250V insulation testing applies to Class 1 appliances if selected (refer to Technical Information for details to change test voltage).*

In some situations, if the DUT is labelled with “Surge Protection Fitted” or if it contains MOV’s (Metal Oxide Varistors), conduct a 250V-insulation test. If unsure refer to the AS/NZS 3760:2022 Standard. Should it still fail, remove it from service. (Refer to the Technical Information section to change test voltage).

*Note: Ensure that the device is isolated from any ground loop.*

#### Procedure:

1. Complete a Visual Inspection.
2. Plug device into appliance test socket.
3. Plug the IEC Clamp Cable into the IEC socket of your Wavecom Appliance Tester
4. Connect earth clip to any exposed metal on the device. If this is not possible, you can use a metal mesh braid to establish an earth connection (sold separately)
5. Navigate to Main Menu A, then Press the F1 key to begin the test
6. The test will be conducted
7. Once complete, read and record results appropriately

If the result was a **PASS** - Tag with PASS tag showing “next test due” date and return the device to service.

If the result was a **FAIL** - Tag the DUT with a DANGER tag and remove the device from service.

### Class 2 Test - Double Insulation Test – Menu A - F2

**The Double Insulation Test completes the following test sequences as part of its procedure:**

1. Integrated Supply Mains Test - Refer to Integrated Test section
2. Integrated NCNT Test Refer to Integrated Test section
3. Double Insulation Test (@250V or 500V): pass level greater than 1MΩ

#### Procedure:

1. Complete a Visual Inspection, and inspect the compliance plate to ensure the appliance is a Class 2 appliance. Look for the double insulated symbol, seen here.
2. Plug the appliance into the appliance test socket of your Wavecom Appliance Tester
3. Navigate to Main Menu A, then Press the F2 key to begin the test
4. Read and record results appropriately



If the result was a **PASS** - Tag with PASS tag showing “next test due” date and return the device to service.

If the result was a **FAIL** - Tag with a DANGER tag and remove the device from service.

*Note: In some situations, if the device is labelled with “Surge Protection Fitted” or if it contains MOV’s (Metal Oxide Varistors), conduct a 250V-insulation test. Always read the compliance plates before testing, especially on surge protected powerboards. If unsure always refer to the AS/NZS 3760:2022 Standard. Should it still fail, remove it from service.*

## **Lead Test (Extension Lead Test) – Menu A - F3**

*Note: Extension leads should always be uncoiled before using or testing. Please ensure that the IEC Adaptor & the IEC socket are inserted firmly or it may result in a continuity/polarity fail.*

**The Lead Test completes the following sequence as part of its comprehensive testing procedure:**

1. Integrated Supply Mains Test - Refer to Integrated Test section
2. Earth Bond Test (@ 200mA): 200mA test current, pass level less than 1Ω
3. Insulation Test (@ 250V or 500V): pass level greater than 1MΩ
4. Continuity and Polarity Test 240VAC @ 2mA Checks continuity & polarity of leads

### **Procedure:**

1. Complete a Visual Inspection
2. Plug in the IEC-550 Orange Lead adaptor lead supplied into the IEC socket.
3. Plug male end of extension lead or power board into the appliance test socket.
4. Connect the IEC-550 Orange lead to your extension lead
5. Navigate to Main Menu A, then Press the F3 key to begin the test
6. Read and record results appropriately.
- 7.

If the result was a **PASS** - Tag with PASS tag showing “next test due” date and return the device to service.

If the result was a **FAIL** - Tag with a DANGER tag and remove the device from service.

## Testing Menu – Main Menu B

TnT EL

TnT RCD

TnT Titan

Use the Enter button to switch between Menu A and Menu B. All tests on Menu B require a Mains Power source. **Your Wavecom Appliance Tester 20A must be connected to Mains via the provided Power Adaptor when testing.**

## Power Test - Menu B – F1

TnT EL

TnT RCD

TnT Titan

The Power Test is for the purposes of monitoring and performance of equipment. The Power Test feature is for single phase appliances only. The Power Test allows the user to turn the appliance on and measure its performance as a digital wattmeter.

Displayed parameters are:

- Volts AC
- Current
- Volt Amp
- Power Factor
- Watts

This test is ideal for service agents and electricians. The user can plug in the appliance and turn it on with real time measurements displayed on the display. This is useful when testing an appliance with a compliance/ name plate on it. The operator can compare the name plate details of operating voltage, operating current, and power factor etc. Should the appliance exceed the said values on the name plate it could be deemed faulty and require service.

### The Power Test completes the following sequence as part of its comprehensive testing procedure:

1. Integrated Supply Mains Test - Refer to Integrated Test section
2. Power Test

**Caution:** Before operating ensure the equipment is firmly secured to eliminate the possibility of causing injury or damage. This function will power the appliance on, and in the case of appliance with movable parts these parts may begin to move. Ensure the appliance can power on safely before proceeding.

### Procedure:

1. Complete a Visual Inspection. If the unit passed the Visual Inspection, continue with the following instructions. If not, refer to the First Test section.
2. Ensure the appliance is safely located and secured, as it will be powered and operational during this test.
3. Plug male end of appliance into Appliance Test Socket.
4. Press F1 to start the power test.
5. A warning message will appear on screen. If the appliance is safely located and secured press F3 to proceed. The unit will power on.
6. Read and record results appropriately.
7. Once the appliance has powered down and the test is complete, unplug the unit.
8. Press Enter to return to the main menu.

*Note: Because the power test is not required in the electrical testing standards there is no pass/fail value built in to the tester. It is up to the user to determine if the item is a pass or a fail based on the compliance/name plate.*

If the result was a **PASS** - Tag with the appropriate tag including “next test due” date and “return to service”.  
If the result was a **FAIL** - Tag with a DANGER TAG and remove the unit from service.

## Leakage / Run Test – Menu B – F2

TnT EL

TnT RCD

TnT Titan

*Note: Leakage Tests can only be conducted when connected to mains power.*

The Leakage Test is an alternate method to perform insulation resistance tests. Leakage testing is a major function of your Wavecom Appliance Tester. There are three types of Leakage test available on your Wavecom Appliance Tester - take care to ensure you use the correct test for your appliance.

This test determines errors of leakage not otherwise detected in a normal insulation test. If there are any doubts with insulation testing of the equipment, the Standard (AS/NZS 3760:2022) allows for a leakage test to be carried out instead. Your Wavecom Appliance Tester has been designed to perform these tests. The Leakage Test applies power to the Device Under Test and measures any imbalance or leakage current. The leakage is tested to the limits of the class types specified in the Standard AS/NZS 3760:2022 i.e. Class 1 = > 5mA as Fail.

The limit of imbalance measured on your Wavecom Appliance Tester will read well in excess of the limits set in mA. However, should the supply circuit be protected by an RCD this device will trip anywhere between 10 to 30mA and trip the mains supply switch OFF. The Leakage Test allows the user to operate the appliance in normal operation conditions and measure its Operating Leakage current. The displayed parameter is mA. The mA Display Range 0.0 to 22.0 mA.

A predefined value for individual class types is programmed into your Wavecom Appliance Tester. These limits are set according to the AS/NZS 3760:2022. Should these values change in future it can be simply altered in firmware. The run time period can be adjusted (by 5 second increments). The value can be changed by selecting the leakage test time in the options menu. The factory default setting is 20sec. The value for the leakage runtime is also used for the power test.

**Caution:** Before operating ensure the equipment is firmly secured to eliminate the possibility of causing injury or damage. This function will power the appliance on, and in the case of appliance with movable parts these parts may begin to move. Ensure the appliance can power on safely before proceeding.

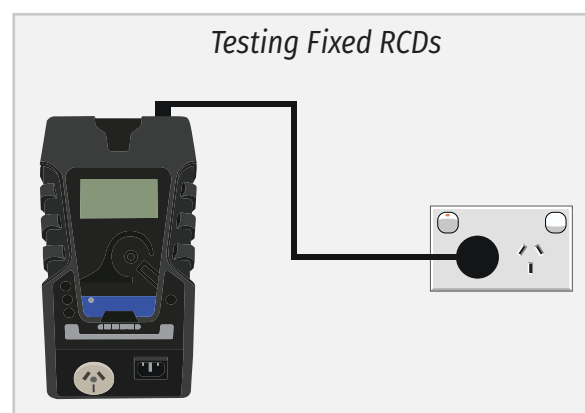
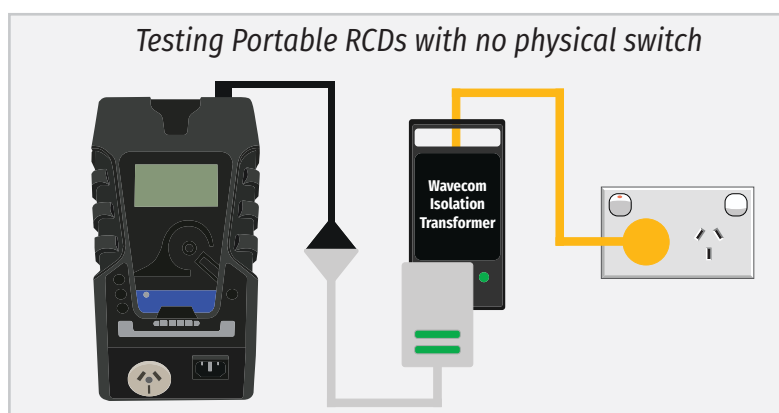
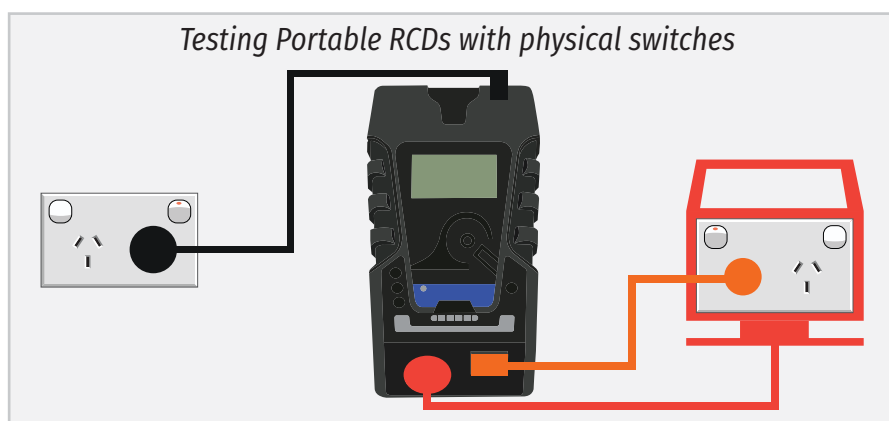

**Procedure:**

1. Complete a Visual Inspection. For details refer to the First Test section. If the device passed the Visual Inspection, continue with the following instructions, if not, refer to the First Test section
2. Ensure that the appliance is safely located as it will be powered and operational during this test.
3. Plug the appliance into the Appliance Test Socket of your Wavecom Appliance Tester
4. If testing a Class 1 Appliance, plug the IEC Clamp Cable into the IEC socket of your Wavecom Appliance Tester, then clamp it onto earthed metal on the appliance
5. If testing an RCD, plug the IEC-550 Orange Cable into the IEC socket of your Wavecom Appliance Tester, then plug it into a socket on your RCD and turn that switch on
6. Navigate to Main Menu B, then press F2 to enter the Leakage Test Menu
7. Press a function key to start the test
  - F1 = Earth Leakage, limit set to MAX then 5mA fail
  - F2 = Double Insulated Leakage and Extension Leads, limit set to MAX then 5mA fail
  - F3 = RCD Leakage (not a full RCD Trip Time or Ramp Test)
8. Your Wavecom Appliance Tester will conduct the first part of the test without powering the appliance
9. A warning will be displayed on screen - ensure the appliance is safely located, then press F3 to power the appliance and continue the leakage test
10. Your results will appear on the screen - If you have a Wavecom tag printer you can now print the tag, otherwise you can now end the test.

If the result was a **PASS** - Tag with the appropriate tag including “next test due” date and “return to service”

If the result was a **FAIL** - Tag with a DANGER TAG and remove from service.

**RCD Tests – Time Test / Ramp Test– Menu B – F3****TnT RCD****TnT Titan****Before Testing**

When any RCD testing is to be carried out on any circuit that is protected by an RCD in the main switchboard (upstream), it's most likely to trip this upstream RCD. When performing RCD Trip Time or Ramp current tests on any portable RCD devices, the RCD in the switchboard may trip faster. This is due to increased upstream levels of leakage current from the additional circuits and devices connected to it. The fixed RCD's may also have better connectivity, sensitivity and mechanical mechanisms.

To avoid tripping large areas in the work place monitored by the switchboard RCD it is suggested that an Isolation Transformer be used. Wavecom Instruments offer an Isolation Transformer, designed specifically for the purposes of field RCD tripping. Do not use these transformers for any other purpose. Rated 240VAC In, 240VAC Out @ 30VA. Fuse protected, Primary Winding 500mA.

**Types of RCD**

There are two types of RCD - Type 1 and Type 2:

Type 1 - Has a trip time of < 40mS and a trip current of < 10mA. These types of RCD's are mainly used on sites containing medical equipment. These types of RCD's must be compliant with AS3551. (Please refer to this AS3551 standard if unsure)

Type 2- Has a trip time of < 300mS and a trip current of < 30mA. Unless specified on the RCD device nearly all RCD will be this type. This is the default setting on all new units.

**RCD Testing Setup**

When testing RCDs, different kinds of RCDs will require different test setups. Consult the diagrams below to determine which setup is required for your situation.



### *RCD Trip Time Testing:*

This test is designed to trip RCD devices at a fixed current and to determine the trip time of the RCD device. During an RCD Trip Time test, your Wavecom Appliance Tester injects a true fault current value using a real-time compensation calculation of the actual voltage at the time of test, delivering a true and accurate trip current. Your Wavecom Appliance Tester will measure the time the RCD takes to trip in milliseconds, and display it on the screen. This function is factory set to 30mA for fast testing, but the user can set the current to x0.5, x1.0 or x5.0 using the RCD Multiplier.

#### *For example:*

30mA \* 0.5 = 15mA

30mA \* 1.0 = 30mA - This also is effective on any set test current of the RCD tester from 5mA to 500mA output.

30mA \* 5.0 = 150mA

These tests should result in no-trip, trip & fast trip times respectively.

To enter the RCD menu from Main Menu B, press the F3 button. Then, to set up a Trip Time Test, press F1. Before performing an RCD Trip Time Test, your Wavecom Appliance Tester should be configured to ensure an accurate result.

### **RCD Test Options:**

To adjust the Trip Time test options, press F3. This allows the user to set the trip current level, 5mA to 500mA. The RCD type can also be selected here depending whether the unit is a Type I or Type II RCD. From the options menu, press F2 to change the current level and F3 to change the RCD type.

### **Adjusting the current level:**

Your Wavecom Appliance Tester displays and maintains the last set trip current value. If the user wishes to change the value of the trip current the following steps enable the changes. Press F2 from the options menu to display test current.

F1 - Raises the trip current in 1mA increments to 500mA. Hold the button and the value will scroll faster the longer it is pressed. Once 500mA limit is reached the value will then loop over and start again from 0mA

F2 - Decreases the trip current in 5mA increments. Hold the button and the value will scroll faster the longer it is pressed. Once 0mA limit is reached the value will then loop over and start again from 500mA.

Enter - Sets the selected current for the next trip time test. Your Wavecom Appliance Tester will then return to the current trip time test screen.

### **Changing RCD Type:**

Depending on the RCD, the RCD type needs to be selected from the options menu. These options change the pass / fail values when performing RCD tests. Please make sure that you have the correct RCD type selected.

F1 - Sets RCD Type to Type 1

F2 - Sets RCD Type to Type 2

You will be prompted to enable or disable Portable RCD (PRCD) testing - unless you are testing a switchboard RCD, turn PRCD on.

### **Conducting the Trip Time Test**

1. Complete a Visual Inspection. For details refer to the First Test section. If the device passed the Visual Inspection, continue with the following instructions, if not, refer to the First Test section.

2. Navigate to Main Menu B, and press F3 to enter the RCD Menu, then press F1 to select Time Test
3. Press F3 to enter the Time Test options menu, to ensure your Wavecom Appliance Tester has the correct settings for the type of RCD
4. Once your Wavecom Appliance Tester is set up correctly, select either the 0° (Positive) or the 180° (Negative) Phase to test. Both phases should be tested, and after the first test, you can select 'Retest' to test the other phase.
5. When ready, press F3 to begin the test - the RCD will trip, and the time will be recorded in milliseconds.
6. Wavecom Appliance Tester will switch to battery power (if charged) and stay on, but will need to be Mains Powered again to conduct further RCD tests.
7. You can now retest the other phase of the RCD, or simply print your tag and record your results.

### *RCD Ramp Testing*

This test is designed to trip RCD devices using a ramping up current value, to determine the trip current of the RCD device. This useful test allows the user to determine circuit leakage load/pre-loading of RCD circuit. This can assist in determining nuisance tripping issues (RCD is too sensitive) or determining RCD performance if suspected faulty or inconsistent in performance. Your Wavecom Appliance Tester has a nominal leakage current of 2mA, which should be added to the result of test.

E.g. if RCD tripped at 22mA, add 2mA to get a value of 24mA trip current.

To enter the RCD menu from Main Menu B, press the F3 button. Then, to set up a Ramp Test, press F2. Before performing an RCD Ramp Test, your Wavecom Appliance Tester should be configured to ensure an accurate result.

#### **Changing RCD Type:**

Depending on the RCD, the RCD type needs to be selected from the options menu. These options change the pass / fail values when performing RCD tests. Please make sure that you have the correct RCD type selected.

F1 - Sets RCD Type to Type 1

F2 - Sets RCD Type to Type 2

You will be prompted to enable or disable Portable RCD (PRCD) testing - unless you are testing a switchboard RCD, turn PRCD on.

#### **Conducting the Ramp Test**

1. Complete a Visual Inspection. For details refer to the First Test section. If the device passed the Visual Inspection, continue with the following instructions, if not, refer to the First Test section.
2. Navigate to Main Menu B, and press F3 to enter the RCD Menu, then press F2 to select Ramp Test
3. Press F2 to select your RCD Type, and turn Portable RCD testing on or off
4. Press F3 to begin the test - your Wavecom Appliance Tester will increase the current to the RCD until it trips, displaying the current on screen.
5. Your Wavecom Appliance Tester will switch to battery power (if charged) and stay on, but will need to be Mains Powered again to conduct further RCD tests.
6. You can now print your tag and record your results.

## Meter Mode®

TnT EL

TnT RCD

TnT Titan

### Meter Mode Features

Electrical parameters are displayed as Volts, Amps, Watts, and Volt / Amps. These electrical parameters will be displayed on the Testers main screen display. Select from the 4 Test available in Meter Mode.

Meter Mode measures and displays volts in AC, Current in Amps, Power Measurement in Watts and VA in Volt/ Amps

### Typical Applications

- Measuring the Power of a bar heater, or electric power drill
- Check appliance ratings and compare them to that on the compliance plate
- Quick test of Power outlet Voltages in rooms or locations split from multiple circuits.

### How to use Meter Mode

1. Conduct a visual inspection, and inspect the compliance plate to determine the expected results
2. Plug in the appliance to the appliance test socket on your Wavecom Appliance Tester.
3. Ensure the appliance is safely located and secured, as it will be powered during this test.
4. Press and Hold F3 to enter Meter Mode
5. When ready, press F3 to begin Meter Mode, then press F3 to power the appliance.
6. Press F3 to scroll through the options (Volts, Amps, Watts & Volt/Amps in that order)
7. To end Meter Mode, simply press Enter, then to leave Meter Mode and return to the Menu, press Enter again. Your Wavecom Appliance Tester will stay in Meter Mode when powered off

### Explanation of Electrical Parameters

#### Volts

A volt is the unit used to measure the energy available in the electrical current of a circuit. Voltage controls the available electrical power (wattage).

#### Amperes (aka Amps)

An amp is the unit used to measure electrical current as it flows past a specified point.

#### Watts

A watt is the unit used to measure the amount of actual flowing electrical energy.

#### Volt-Amps

A volt-amp is the unit used to measure the apparent electrical power used by computing equipment. Mathematically, it is expressed as volts times amps (V\*A). Because it represents the amount of energy computing systems may draw from a power grid, Volt-Amp measurements are used to determine the kind of wiring and circuit breakers required to support the computing equipment in question.

#### Watts and VA - Detailed Explanation

The power drawn by equipment is expressed in Watts or Volt-Amps (VA). The power in Watts is the real power drawn by the equipment. Volt-Amps are called the "apparent power" and are the product of the voltage applied to the equipment times the current drawn by the equipment. Both Watt and VA ratings have a use and purpose. The Watt rating determines the actual power purchased from the utility company and the heat loading generated by the equipment

### Disclaimer

Meter Mode is to be used for quick simple indicative electrical parameter measurements. Providing reasonably accurate readings without the need to carry any other instruments. It is not intended to replace specific, more accurate individual test equipment, nor is its purpose to replace prescribed testing requirements. In doubt please consult a qualified electrician when unsure or perform proper test procedures.

# Specifications

TnT EL

TnT RCD

TnT Titan

## Mains Supply Test

Checks Polarity and continuity of mains supply by LED indicators (A-N, A-E, and N-E). (Flashing red LED indicates test fail)

## Class 1 Earthed Appliance

Appliance Check: Ensures appliance is plugged in and turned on.

Earth Bond Test: 200mA test current. Pass level Less than 1.0  $\Omega$ . Measurement: 0.01 $\Omega$  to 10  $\Omega$ .

Insulation Test: 500VDC / 250VDC. Pass level Greater than 1M  $\Omega$ . Measurement: 0.1 $\Omega$  to 10M $\Omega$ . \*See also Leakage Test

## Class 2 Double Insulated Appliance

Appliance Check: Ensures appliance is plugged in and turned on.

Insulation Test: 500VDC / 250VDC. Pass level greater than 1M $\Omega$ . Measurement: 0.1 $\Omega$  to 10M $\Omega$ . \*See also Leakage Test

## Extension Leads

Earth Bond Test: 200mA test current. Pass level Less than 1 $\Omega$ . Measurement: 0.01 $\Omega$  to 10.0 $\Omega$ s

Insulation Test: 500VDC / 250VDC. Pass level Greater than 1M $\Omega$ . Measurement: 0.1 $\Omega$  to 10.0M $\Omega$ .

Continuity/Polarity Test: 250VAC check continuity and polarity of leads. Displays Pass/Fail.

## Leakage Test

Leakage Current: 0 to 30.0mA at 200 to 265V

Earth Leakage Test: 240VAC Mains. Pass level 1, 2.5, 5.0 mA leakage test levels with up to 10 Amp load operation (20 Amp load for TnT EL 20A, TnT RCD 20A and TnT Titan 20A)

Note 1: Pass level for CLASS 1 is 5 mA; pass level for CLASS 2 is 1 mA

Note 2: Leakage test may be performed if for any reason a standard CLASS 1 or CLASS 2 is not possible.

## RCD Test

TnT RCD

TnT Titan

Trip Current: 2 to 500mA in 1mA steps. User selectable.

Trip Time: 0 to 3,000ms at .001sec resolution.

Current Ramp Trip Test: 0 to 500mA in 1mA increments.

## Power Measurement

Leakage Current: 0 to 30.0mA at 200 to 265V

Load Current: 0.0 to 10Amp (20Amp for TnT EL 20A, TnT RCD 20A and TnT Titan 20A)

Voltage: 200 to 265VAC

Power Factor: 0.00 to 1.00

Apparent Power: 0 to 2400VA

Power: 0 to 2400W

## Meter Mode<sup>®</sup>

Green flashing LED denotes MM is engaged

Load Current: 0.0 to 10Amp

Voltage: 200 to 265VAC

Apparent Power: 0 to 2400VA

Power: 0 to 2400W

Apparent Power: 0 to 2400VA

Power: 0 to 2400W

# Technical Information

TnT EL

TnT RCD

TnT Titan

## Visual Inspection

Visual inspection has to be done before any other test is carried out using your Wavecom Appliance Tester.

The visual inspection is carried out to ensure there are no physical faults with the appliance before testing. The following list is an example of potential physical faults, but it is not exhaustive and the relevant standards must be consulted to ensure a proper Visual Inspection is undertaken.

- There is no damage or component defects to the accessories, plugs, outlet sockets or connectors (physical).
- There are no cracks &/or abrasions.
- There are no exposed inner cores or conductors (flexible) and the supply cords are not twisted or distorted.
- Any Fuse / Over load protection components (if fitted) are checked.
- All labels, markings and warning indicators (of the maximum load to be connected to the device) are legible and intact.
- The insulation is not damaged in any way i.e. melted, cuts or abrasions. There are no iron filings in the insulation. There is no insulation tape on the lead.
- Any flexible cords and/or leads are effectively anchored (glands and grommets intact).
- All covers or guards are in place and secure as intended by the supplier/manufacturer.
- All safety devices and systems are in good working order. (i.e. overload latches & buttons).
- No dust &/or dirt obstructs any exhausts or ventilation outlets.
- All controls are working properly and are secure and aligned.

### Important - If Result is a Fail:

If any Equipment fails **ANY** of the above, it should be deemed to have **FAILED** the Visual Test, and therefore no other tests need be performed. If this is the case the Equipment should be tagged with a DANGER TAG and removed from service. **It is recommended by the manufacturer and distributor of this product that it SHOULD NOT BE RETURNED TO SERVICE. To do so would be considered unsafe.**

## Class 1 (Earthed Appliance) Construction

### Single basic insulated and protectively earth equipment

This type of product design provides two safety barriers between all live conductors at dangerous voltages and the equipment user.

The provision of basic insulation between exposed metal parts and live parts is the first barrier to provide basic protection against electric shock.

The second safety barrier is by the connection of exposed (accessible) conductive (metal) parts to the protective earthing conductor (earth wire) in the fixed wiring of the device/Installation.

The protective earthing terminal of the equipment must be marked with the word "earth" or the symbol "E" or the symbol for Earth Terminal or Protective.

To perform this test, a continuous earth loop must be made between the exposed conductive material (metal) and your Wavecom Appliance Tester appliance tester. This is done by means of connecting the earth lead

with the crocodile clip/probe attached to a GOOD earth point (paint & coatings will not provide effective connections) and the appliance plugged into your Wavecom Appliance Testers' test socket. The Maximum allowable limit is less than 1.0Ω.

## ***Class 2 (Double Insulated) Construction***

### ***Double insulated equipment***

This method of construction employs two safety barriers comprising two layers of insulation between dangerous voltages and the user of the equipment.

The first layer of insulation is formed around the live conductor and is termed 'the Functional Insulation'.

The second layer of insulation is termed 'the Supplementary Insulation'. In Class II equipment, protection against electric shock does not rely on basic insulation only, but has additional supplementary insulation such as double insulation or reinforced insulation provided, there being no reliance on precautions in the fixed wiring of installation.

Class II equipment is marked with the words "DOUBLE INSULATION" or the symbol:



For double insulated under Safety Symbols:

*Note 1 – Double Insulation is insulation comprising both basic and supplementary insulation.*

*Note 2 – Reinforced Insulation is a single insulation system with a degree of protection against electric shock, which is equivalent to double insulation.*

## ***Testing of Electrical Equipment***

Many testing personnel have some reservations in testing sensitive, electronic equipment using a 500V DC insulation test. There is a perceived fear of causing internal damage from over voltage. With Wavecom Appliance Testers these concerns are alleviated.

Your Wavecom Appliance Tester can safely test electronic equipment as the tests are carried from Active-Neutral (shorted by a relay inside the tester) to Earth. In this mode no dangerous voltages pass through to the internal components of the appliance, or Device Under Test ('DUT'). If these tests are done using an Insulation Tester and the user tests Active to Neutral, this could potentially cause damage.

Some changes may be required in certain configurations where fitted surge protection devices (MOV's) in the DUT may cause a failed test result. Applying 500V in these situations can cause the surge protection devices to trip, therefore conducting the applied voltage to earth, thus showing a failure of insulation. In these instances the test voltage should be changed to 250V, then the DUT should be retested. If the DUT still fails, check with the DUT Operators' Manual or an electrician. (for details see - 'Double Insulation Test' 250/500VDC to change test voltage).

Under these circumstances, it would be difficult for any damage to occur to either the surge protection device or the DUT, as there is insufficient current generated by your Wavecom Appliance Tester.

## Leakage Test

If there are any doubts with insulation testing of the equipment, the standard (AS/NZS 3760:2022 since 2001) allows for an alternative test method. A Leakage Test can be performed instead. (Your Wavecom Appliance Tester is designed to perform these tests).

*NOTE: The maximum resistive load for the TnT EL, TnT RCD & TnT Titan is 10 Amps, and the maximum load for the TnT EL 20A, TnT RCD 20A, and TnT Titan 20A is 20 Amps*

A Leakage Test applies power to the Device Under Test (DUT) and measures the imbalance of leakage current from the DUT between the active and neutral conductors. The leakage is tested to the limits specified in the standard and a Pass/Fail result as well as a digital reading is provided to ensure that the user gains as much information as necessary.

## Earth Continuity Test - Commonly called Earth Bond Test

*Note: Part of normal (Class 1 test) procedure. Use supplied IEC-Alligator Clip lead or optional accessory 'WCM-Probe kit'*

Your Wavecom Appliance Tester conducts earth continuity tests at Approx. 200mA. Continuity tests at higher currents are not required or recommended on certain equipment as this may cause severe damage or premature failure to the Device under test (see AS/NZS 3760:2022).

## Unique Earth Bond Test Feature

*Note: Test time with the your Wavecom Appliance Tester can now be user controlled. This function enables testing personnel to extend the Earth Bond test time by 30 second increments. This is achieved by momentarily pushing the ENTER button once, during the test.*

Your Wavecom Appliance Tester will then add 30 seconds to the test time for ENTER button press. This feature has been incorporated to provide extra time to achieve an adequate physical connection, or confirm any possible INTERMITTENT issues. There may be situations where the condition of equipment, coatings applied, or suspect wiring breaks may alter the earth connection path of the device under test.

Benefit to test personnel is to save time by not having to continually repeat tests in a less than perfect situation.

## 3 Phase Testing

*Note: 3 Phase Testing requires a three phase adaptor, sold separately. Wavecom Handheld Appliance Testers cannot perform a 3 Phase Leakage test.*

3 Phase appliances can be tested by your Wavecom Appliance Tester. As the insulation tests are from Phase to Earth, only a 500V insulation test is required. This test may be carried out by using the optional adaptor 'WCM-3PH-MADP' [See 'Optional Accessories' for details.]

To change the test voltages, when in Main Menu A; Press Enter and F2 together to enter in settings. Select "Change Insulation Vol" and press enter. Select either 250V or 500V. Your Wavecom Appliance Tester defaults to 500VDC, and will revert back to that when restarted.



## Integrated Tests

### Mains Supply Test

*Note: The Mains Supply Test only applies when connected to Mains Power - if you are using your TnT RCD or TnT Titan in battery mode, you can disregard this.*

The Supply Mains Test checks the polarity and connectivity of the mains supply by LED's. This test is also a part of all the testing functions of this unit.

If the central N-E light is on (red) and you need to conduct load/leakage tests DO NOT CONTINUE. If you are carrying out standard Insulation and Earth Bond tests, it is generally safe to continue. This light will glow if a voltage difference lies between the neutral and the earth, or if no earth is connected to your Wavecom Appliance Tester's supply. (If working with a generator or inverter, this is most likely to occur and you may need to consult an electrician before proceeding).

If both the A-E & A-N (green) lights are on but not the N-E (red), the Mains Supply Test has passed and you can continue with your testing. If both of the N-E (red) & A-E (green) lights are on, consult an Electrician, as there is a fault with the Mains Supply.

*Note: While in Battery mode, all LEDs will be off as no mains connected and supply mains test is not carried out.*

### No Connection No Test

This test function ensures that the appliance is plugged into your Wavecom Appliance Tester and that it is switched on. If the device is not plugged in and your Wavecom Appliance Tester detects that no device is present, and prompts the user to plug in an appliance to continue the test or press 'QUIT' to return to the main menu.

If for some reason the NCNT circuit does not detect the device but it is actually plugged in and turned on, the operator will need to override the NCNT function.

To do this Over Ride Press F3 - Done with User Discretion

With an emphasis in the Standard AS/NZS 3760:2022 for carrying out the live testing your Wavecom Appliance Tester appliance testers will indicate for you to check if the device is plugged in and switched on. If the device is not plugged in and/or recognised, it may require a live test therefore making it necessary for the operator to carry out a full functional Leakage Test.

This function is to ensure that correct testing procedures are carried out in accordance with the Standard AS/NZS 3760:2022.

\*Optional

*Note: When using 3-Phase adaptors the NCNT function will need to be over ridden by pressing the 'OK' key prior to your Wavecom Appliance Tester performing the assigned test. Some single-Phase appliances controlled by contactors will also require manual over ride. In some instances, holding the 'ON' button will enable the NCNT function to work normally.*

# Wavecom Tags & Accessories

TnT EL

TnT RCD

TnT Titan

To support our test and print units we offer to you our range of electrical test tags that are made of the highest grade polypropylene and polyester label materials. These materials are robust and resistant to tearing and will cope with harsh Australian environments. It is recommended in extreme external conditions you use UV resistant tags

## Wavecom Tags

The test tags/labels we offer come in the full range of colours, each tag comes with a clear white area where a barcode can be printed into ensuring easy and accurate scanning, this results in the user being able to conduct fast scanning without issues.

### Order Information:

Lightweight ATT Tags (250 Tags)	Suitable for most environments	Part no: WCM-ATT-TAGS-(B, BLK, BUR, GN, O, R, Y)
Medium Duty TT Tags (100 Tags)	Suitable for indoor and outdoor use	Part no: WCM-TT-TAGS-(B, BLK, BUR, GN, O, R, Y, RAIN)
Heavy Duty TM Tags (100 Tags)	Suitable for all but the most extreme environments	Part no: WCM-TM-TAGS-(B, BLK, BUR, GN, O, R, Y)
Super Heavy Duty TA Tags (100 Tags)	Suitable for all industrial and outdoor sites	Part no: WCM-TA-TAGS-(B, BLK, BUR, GN, O, R, Y)

## Optional Accessories

500mm Metal Braid for Earthing Appliances	Part No: TnT-ES 500
3-Phase Adaptor 20A & 32A 5pin + 5pin	Part No: WCM-3PH-MADP
HBC Fuse	Part No: WCM-HBC10AM205
Isolation Transformer for RCD testing	Part No: WCM-ISOT
Probe Kit	Part No: WCM-Probe
WinPATS Extended Support (12 months)	Part No: WCM-WinPATS Support
IEC 20amp-10amp Current Limited Adapter Cable	Part No: WCM-IEC2010 (Suitable for 20A Models Only)

## Disclaimer – E&OE

All specifications may be subject to be change by Wavecom Pty. Ltd. without prior notice.

Updated Specifications & Model changes may be found on the Wavecom website: - [www.wavecom.com.au](http://www.wavecom.com.au)

At the time of developing this manual, all care and consideration for accuracy has been implemented. Wavecom accepts no responsibility for any errors or omissions in this document. This is partly based on the fact that Electronics & Electrical testing and specifications worldwide are constantly changing and that Local, State and National Regulatory Authorities may also have differing or additional requirements. It is strongly recommended the Purchaser check Local Regulatory Standards that may be applicable in your region.

No part of this document may be Reproduced, Copied, Modified or Utilised in any way or form without the permission of Wavecom Instruments in writing.



Tester Serial Number



WinPATS Android App  
Discount Coupon  
*(Valid for one use only)*

## Purchase Information

Date of Purchase

Sold By



**Your Wavecom Appliance Tester is proudly designed  
and manufactured in Australia by Wavecom.**

### Wavecom SA

257 Grange Road,  
Findon SA, 5023

P: 08 8243 3500  
F: 08 8243 3501  
E: [service@wavecom.com.au](mailto:service@wavecom.com.au)

### Wavecom WA

Unit 2/17 Casino Street,  
Welshpool WA, 6106

P: 08 9353 1943  
F: 08 9353 4319  
E: [saleswa@wavecom.com.au](mailto:saleswa@wavecom.com.au)

### Wavecom VIC

Mark Kennedy  
M: 0430 299 164

P: 03 9897 4711  
F: 08 8243 3501  
E: [service@wavecom.com.au](mailto:service@wavecom.com.au)